

DATA SHEET
LOAD REVERSING MODULE
S2

GENERAL

The S2 Drive Selector Module is used with any Drive Module, to reverse the phase of the power delivered to the load.

It is particularly useful for reversing the flow of material with a dual coil feeder, such as the Syntron VPF type.

Lo level signals will reverse the phase of the power delivered to the load.

LED lights indicate the power line phase delivered to resistive or lamp loads.

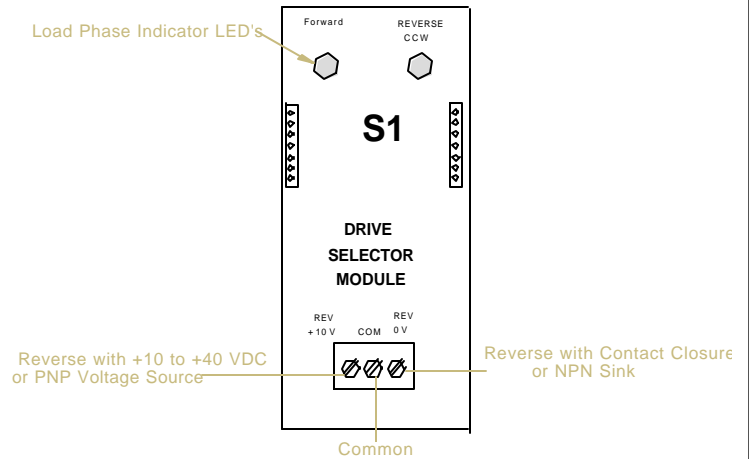

SPECIFICATIONS

To Reverse Direction:

HI : Connect to +10 VDC

Or

LO: Connect to 0 VDC

